



REDEFINING THERMAL PERFORMANCE  
FOR ALUMINIUM HYBRID SLIDE DOORS

# WarmCore<sup>®</sup> Slide Doors



# WarmCore®

## NEXT GENERATION SLIDE DOORS

WARMCORE® INLINE SLIDE DOORS ALLOW NATURAL LIGHT TO FLOOD INTO YOUR HOME THROUGH LARGE GLAZED SASHES THAT MAXIMISE THE ENJOYMENT OF YOUR VIEW.

The full-width thermal core at the heart of the WarmCore® range lets you enjoy the desirability and durability of aluminium, while keeping your home snug and warm.

Custom-designed 5-wheel rollers glide effortlessly on a precision-engineered track, making these panoramic doors the perfect blend of aesthetics and performance.

### BUILT-IN THERMAL PERFORMANCE

U-value  
**1.0** W/(m<sup>2</sup>k)

With triple glazed U-values (used to calculate thermal efficiency) as low as 1.0 and double glazed values of 1.4, your WarmCore® slide doors will help keep heating bills low.

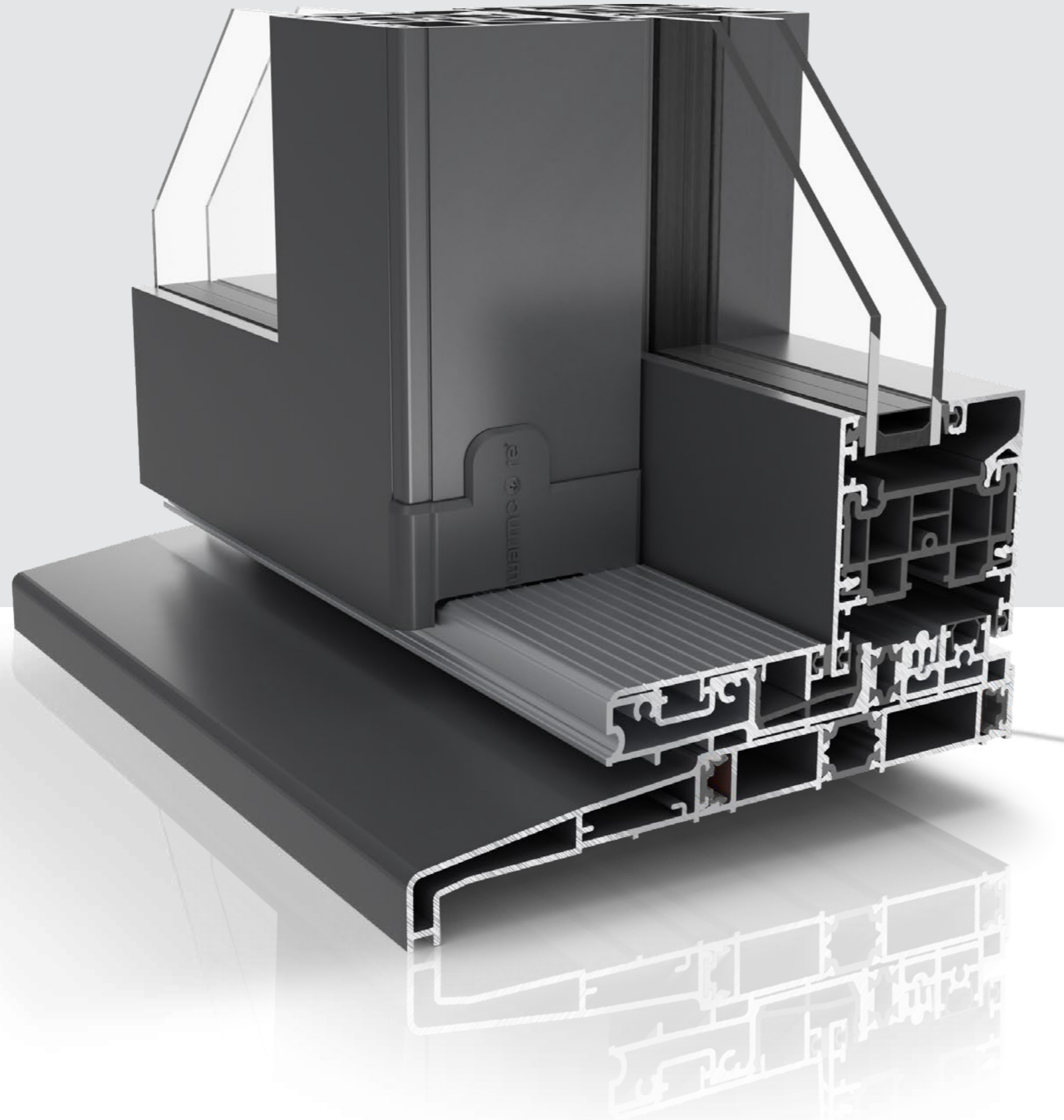

# 10-YEAR GUARANTEE

Peace of mind comes from a comprehensive 10-year guarantee covering surface finish direct from the manufacturer.



# WarmCore®

## SECURITY BUILT IN

FEATURING A BI-DIRECTIONAL LOCK FOR ADDED SECURITY.

WarmCore® slide doors are fitted with a high-security 'Anti-Snap' and 'Anti-Bump' Yale Platinum 3 Star cylinder, designed to provide maximum security against known cylinder attack methods.

For added peace of mind choose the optional laminate glass upgrade – giving WarmCore® slide doors additional security to Secured by Design accreditation.

### Innovative Handle and Lock

With an emphasis on clean, modern aesthetics, we custom-designed a high-quality 'lift-to-lock' handle unique to the WarmCore® slide. This innovative handle operates the bi-directional locks located at the top and bottom of the door. These 'claws' make WarmCore® slide doors incredibly secure helping protect you and your home.

Secured by Design



Official Police Security Initiative



### SECURITY HANDLE COLOUR OPTIONS

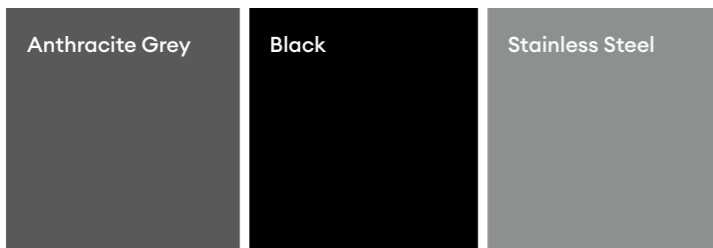

# CLEAN, CONTEMPORARY LINES

## ARCHITECTURAL APPEAL MEETS PRACTICALITY.

We've brought the classic sliding door up-to-date with clean lines, a flush finish and a hard-wearing aluminium exterior, combining architectural appeal with practicality.

With two, three and four-pane configurations you can choose a style that suits both your home and lifestyle, bringing the outside in during summer months and keeping the cold out during the winter.



## THE NEXT GENERATION OF SLIDE DOOR. RELIABLE AND SAFE.

The WarmCore® inline slide uses a unique high-quality wheel-set with each sash running on 10 self-levelling rollers to give you ultra-smooth, reliable performance.

The wheels have been tested to 50,000 cycles, so you know your doors will run effortlessly for years to come.

Our modern safety brakes are an optional add-on to prevent trapped fingers and unintentional slamming, particularly when children are around.

Carefully engineered, built-in safety brakes guarantee a soft, dampened operation, helping prevent misuse.



# FIND YOUR PERFECT COLOUR AND FINISH

Available in a choice of powder coated colours and stunning laminated grained finishes, WarmCore® also allows you to pick a different colour for each side of your slide door.

Want a colour outside with white inside to leave you free to change your interior in the future? – with WarmCore® that's no problem.

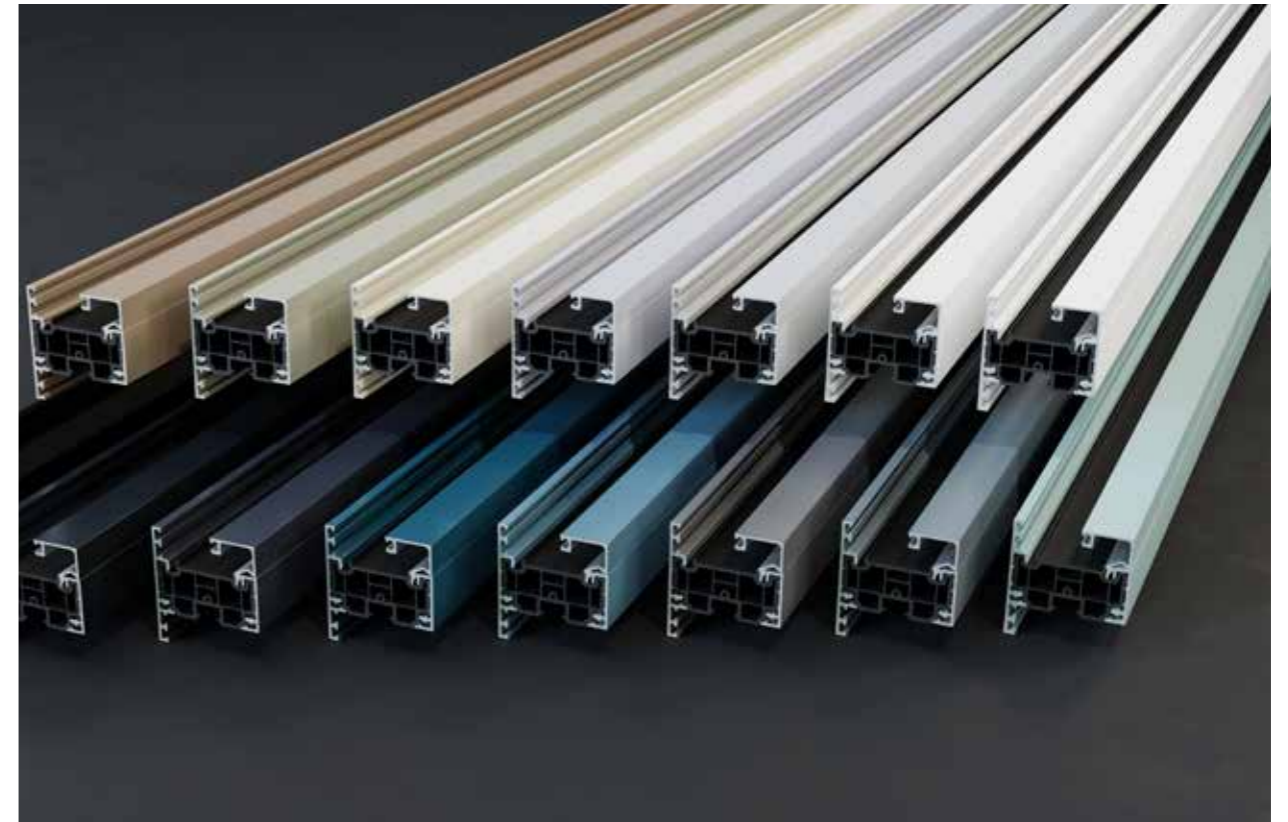

## POWDER COATED COLOURS



## WOODGRAIN FOILS



# THRESHOLD OPTIONS

FLEXIBILITY DESIGNED TO MATCH YOUR NEEDS.

A choice of threshold options, which can be combined with various cills configurations, let you find the ideal solution for your requirements.

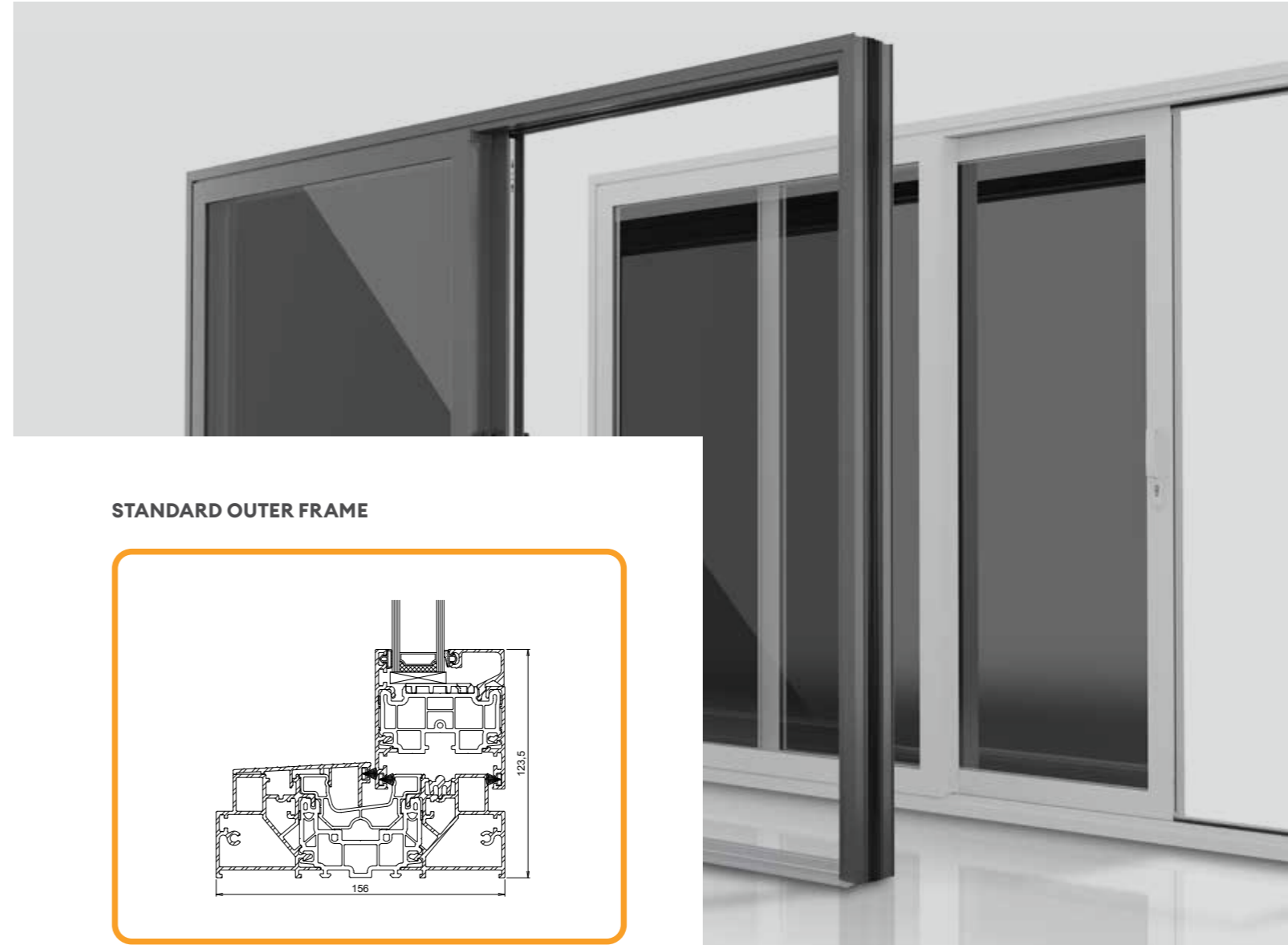

LOW THRESHOLD

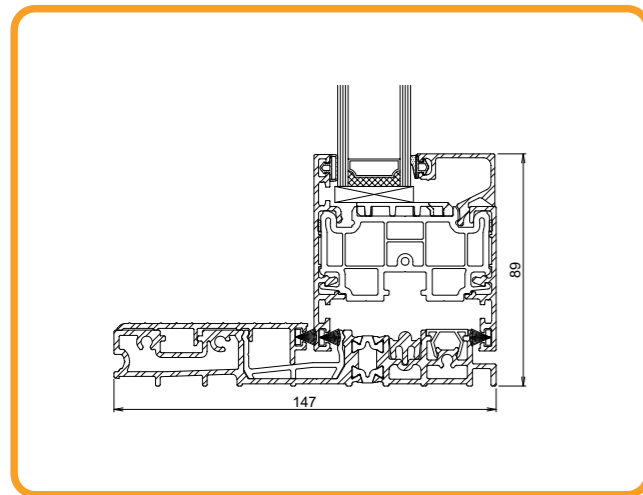

LOW THRESHOLD WITH RAMP

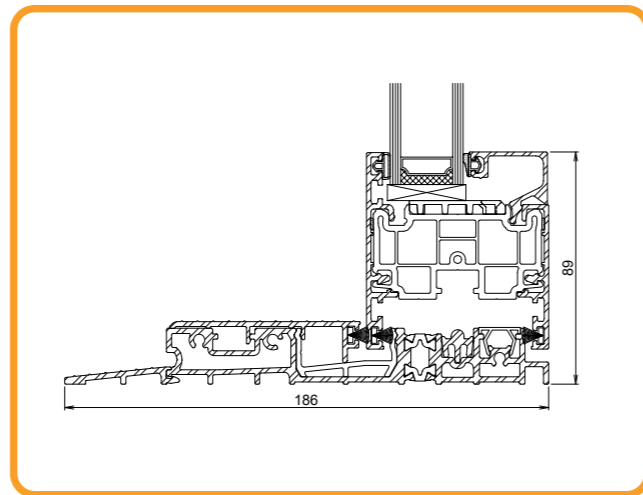

STANDARD OUTER FRAME

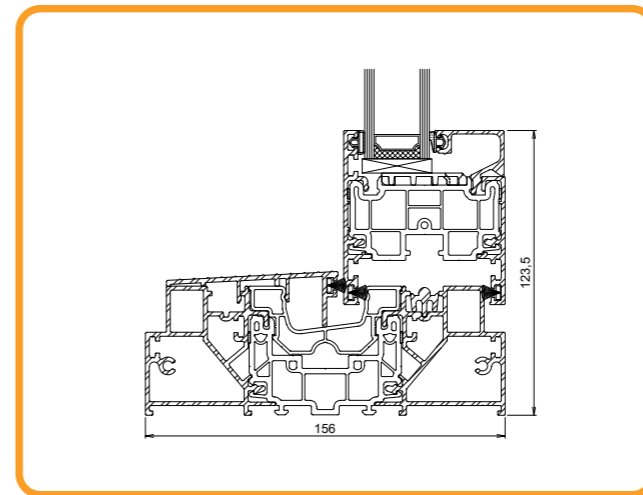

LOW THRESHOLD WITH 210MM CILL

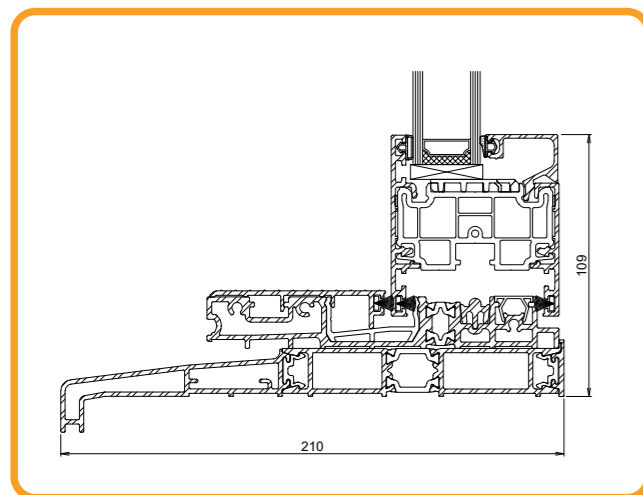

LOW THRESHOLD WITH 240MM CILL

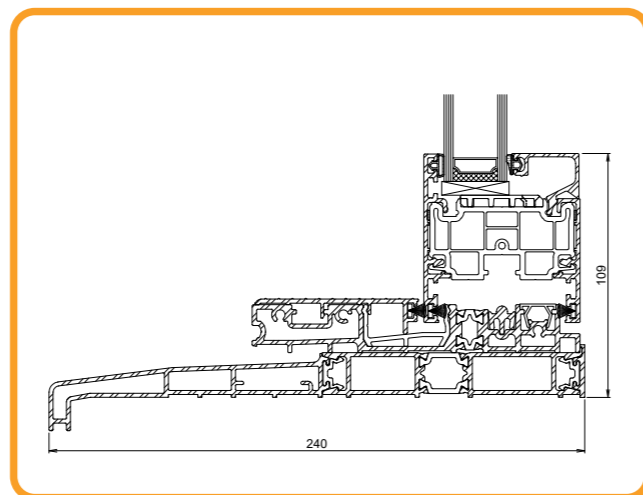

STANDARD OUTER FRAME WITH 210MM CILL

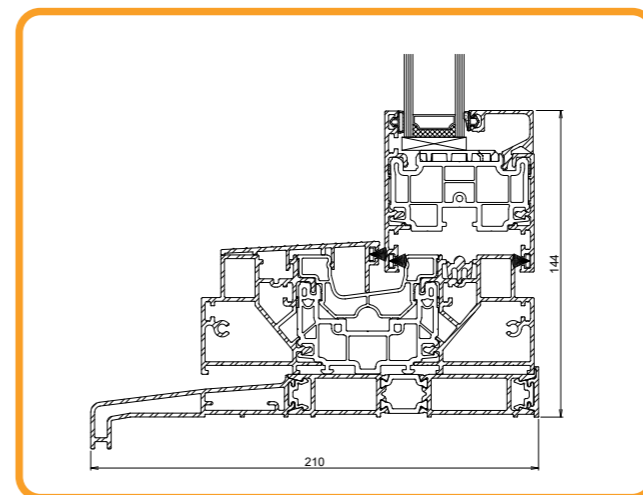

STANDARD OUTER FRAME WITH 240MM CILL

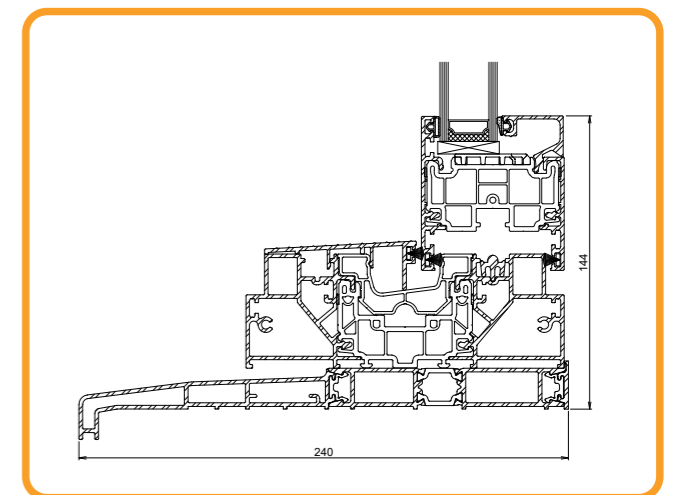

# A WINDOW TO A BETTER WORLD...

IF A PRODUCT IS AESTHETICALLY APPEALING AND HIGH PERFORMING, DOES IT MATTER HOW IT IS MADE? AT KÖMMERLING, WE THINK IT DOES.

We don't believe that beautiful windows and doors should come at the expense of our even more beautiful planet. That's why a commitment to the environment, and to society as a whole, underpins everything we do.

Reflecting this, we were one of the first manufacturers of PVCu windows and doors to replace lead-based stabilisers in our profiles with non-toxic, more environmentally friendly calcium zinc-based alternatives.

We were also a founding member of an industry-wide project to recycle PVCu window and door waste into new windows and doors as well as the first company in the market to obtain 'Zero Pellet Loss' certification. This initiative helps to keep plastic out of the world's oceans and other environments.

The "Kömmerling Better World Stiftung" foundation, meanwhile, is our own not-for-profit charitable organisation. It raises money for a wide range of equally worthwhile causes including the care of the elderly, cancer research and children's homes.



# WarmCore<sup>®</sup>

Secured by Design



Official Police Security Initiative

## #KömmerlingForTomorrow

To discover your local supplier of the WarmCore<sup>®</sup> Fold Door range, call us on **01623 579200**.

[www.kommerling.co.uk](http://www.kommerling.co.uk)

✕ @warmcore\_uk

📷 @warmcore\_uk

 **BLAIRS**  
ALUMINIUM SYSTEMS LTD

**SAVEHEAT**  
GLASS

**SAVEHEAT**  
GLAZING SYSTEMS GROUP

8 - 10 Lovat Place  
Queen Elizabeth Avenue  
Hillington Industrial Estate  
Glasgow G52 4DS

[www.blairsasl.co.uk](http://www.blairsasl.co.uk)  
[sales@blairsasl.co.uk](mailto:sales@blairsasl.co.uk)  
0141 648 0583

[www.kommerling.co.uk](http://www.kommerling.co.uk)

✕ @kommerling\_uk

f KommerlingUK

📷 kommerlinguk

Part of the Saveheat Glazing Systems Group